

4*PWS1-135M-R Rack Solution

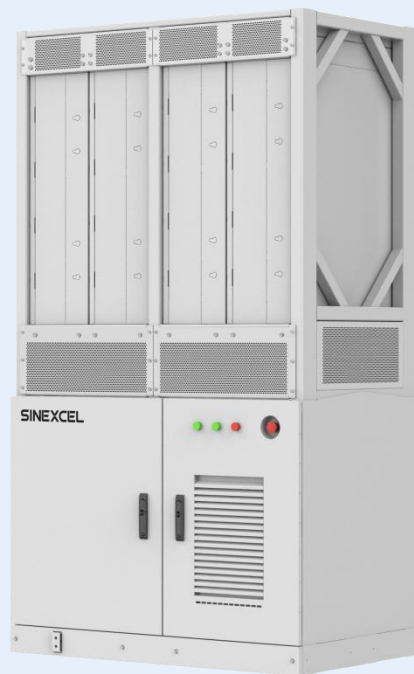

User
manual

Energy Freedom
Driven By **Sinexcel**[®]

Sinexcel

4*PWS1-135M-R Rack Solution

User manual

Version: 1.3

Shenzhen Sinexcel Electric Co., Ltd.

All rights reserved. In case of any content change, it shall be without prior notice.

Shenzhen Sinexcel Electric Co., Ltd.

Website: www.sinexcel.com

Add: Building 6, Area 2, Baiwangxin High-tech Industrial Park, No. 1002, Songbai Road, Nanshan District,
Shenzhen

Hotline: +86 0755-8651-1588

Content

1 OVERVIEW	- 1 -
1.1 APPLICABLE MODELS	- 1 -
1.2 TARGET GROUP	- 1 -
1.3 TERMINOLOGY	- 1 -
2 SAFETY INSTRUCTIONS	- 2 -
2.1 LABELS	- 2 -
2.2 IMPORTANT SAFETY INSTRUCTIONS	- 2 -
2.3 ADDITIONAL INFORMATION	- 3 -
3 PRODUCT INTRODUCTION	- 4 -
3.1 SYSTEM INTRODUCTION	- 4 -
3.2 CIRCUIT SCHEMATIC	- 4 -
3.3 EQUIPMENT APPEARANCE AND LAYOUT OF KEY COMPONENTS	- 5 -
3.4 DIMENSION AND WEIGHT	- 5 -
3.5 HEAT DISSIPATION DESIGN	- 6 -
3.6 INDICATOR LIGHT STATUS OF EQUIPMENT INSIDE THE CABINET	- 7 -
3.6.1 <i>Indicator Light Status of PCS</i>	- 7 -
3.6.2 <i>Indicator Light Status of the U2 Control Box</i>	- 8 -
4 PARAMETERS	- 9 -
5 STORING, LIFTING AND TRANSPORTING	- 11 -
5.1 TRANSPORT AND STORAGE	- 11 -
5.2 TRANSPORT	- 12 -
5.3 UNPACKING INSPECTION	- 14 -
5.3.1 <i>Unpacking</i>	- 14 -
5.3.2 <i>Inspection</i>	- 15 -
6 EQUIPMENT INSTALLATION	- 17 -
6.1 INSTALLATION PROCESS	- 17 -
6.2 INSTALLATION NOTES	- 17 -
6.3 EQUIPMENT INSTALLATION	- 18 -
6.3.1 <i>Basic Requirements</i>	- 18 -
6.3.2 <i>Outdoor Requirements</i>	- 19 -
6.3.3 <i>Foundation support requirements</i>	- 19 -
6.3.4 <i>Space requirement</i>	- 20 -
6.3.5 <i>Ventilation Requirements</i>	- 20 -
6.3.6 <i>Other requirements</i>	- 21 -
6.4 SITE INSTALLATION	- 21 -
6.4.1 <i>Wire Channel Design</i>	- 21 -
6.4.2 <i>Equipment securing</i>	- 22 -
6.5 ELECTRICAL CONNECTION	- 22 -
6.5.1 <i>General Safety Rules</i>	- 22 -

6.5.2 Installation Tools	- 23 -
6.5.3 Wiring Parts	- 23 -
6.5.4 Preparation before Wiring	- 24 -
6.5.5 Wiring methods and cable requirements	- 24 -
6.5.6 Precautions for wiring	- 26 -
6.5.7 Wiring Area Overview	- 27 -
6.5.8 DC Side Wiring	- 27 -
6.5.9 AC Side Wiring	- 28 -
6.5.10 System Grounding	- 29 -
6.5.11 Communication Interface	- 30 -
6.5.12 Installation Checklist	- 31 -
7 OPERATION AND DEBUGGING	- 33 -
7.1 CONTROL METHOD	- 33 -
7.1.1 Ethernet Connection	- 33 -
7.1.2 IP Settings	- 34 -
7.1.3 PCS Module Interface	- 35 -
7.2 POWER ON/OFF	- 35 -
7.2.1 Pre-startup Check	- 35 -
7.2.2 Power-on Steps	- 35 -
7.2.3 Power-off Steps	- 36 -
8 TROUBLESHOOTING	- 37 -
8.1 PRELIMINARY INVESTIGATION	- 37 -
8.2 LED INDICATOR DISPLAY AND TROUBLESHOOTING METHODS	- 37 -
8.3 COMMON FAULTS AND TROUBLESHOOTING METHODS	- 38 -
8.4 OTHER FAULTS	- 40 -
9 MAINTENANCE	- 41 -
9.1 SAFETY DURING MAINTENANCE	- 41 -
9.2 MAINTENANCE PLANS AND SPARE PARTS	- 42 -
9.2.1 Operating environment requirements	- 42 -
9.2.2 Electrical and Fixed Connection Inspection	- 42 -
9.2.3 Clean and tidy	- 42 -
9.3 MAINTENANCE WORK	- 42 -
10 APPENDIX	- 44 -
10.1 QUALITY ASSURANCE	- 44 -
11 CONTACT	- 45 -
INSTALLATION RECORD	- 46 -

1 Overview

1.1 Applicable Models

This file applies to the 4*PWS1-135M-R Rack Solution.

The illustrations in this document are for schematic purposes only; please refer to the actual product for details.

1.2 Target Group

The content described in this document should only be operated by professionals.

Professionals are required to have the following skills:

Understand how the product works and how to operate it.

Understand how batteries work and how to operate them.

Be trained in and understand how to deal with hazards and risks arising from the installation and use of electrical equipment.

Understand the installation and commissioning of electrical equipment.

Understand all applicable standard operating instructions.





Understand and comply with this manual and all safety information.

1.3 Terminology

Terminology	Definition
STS	Static transfer switches
AC	Alternating current
DC	Direct current
BESS	Battery energy storage system
ESS	Energy storage system
EMS	Energy management system
BMS	Battery management system
PCS	Power Conversion System
SLD	Single line diagram
SOH	State of health, expressed in percentage
SCR	Silicon controlled rectifier
DOD	Depth of discharge, expressed in percentage
EOD	End of discharge
SOC	Remaining power, expressed in percentage
UI	User interface
EPO	Emergency power off
SPD	Surge protective devices

2 Safety Instructions

2.1 Labels

Labels	Instruction
 Danger	Indicates a dangerous situation which, if not avoided, will result in death or serious injury.
 Warning	Indicates a dangerous situation which, if not avoided, will result in death or serious injury.
 Caution	Indicates a dangerous situation which, if not avoided, may result in minor or moderate injury.
 Attention	Indicates that property damage will occur if not avoided.
 Instruction	Please note important information, best practice and advice. Note the information used to resolve issues not related to personal injury, equipment damage and environmental degradation.

2.2 Important Safety Instructions

This user manual for the installation and operation of the 4*PWS1-135M-R Rack Solution from Sinexcel.

Please read this user manual carefully before installation.

The equipment must be commissioned and maintained by an engineer appointed by the manufacturer or an authorized service partner. Failure to do so may endanger personal safety and lead to equipment failure. Damage to the equipment caused as a result is not covered by the warranty.

Equipment should not be used in any environment or application associated with life support equipment.

This manual contains important instructions for the equipment of the 4*PWS1-135M-R Rack Solution, which shall be followed during the installation and maintenance of the bidirectional energy storage converter.



Danger

Any touching of the copper strip, contacts and terminals inside the appliance that are connected to the grid circuit may cause a fatal burn or electric shock!

Do not touch any terminals and wires connected to the grid circuit.

Take note of any instructions and safety documents regarding grid connection.



Warning

Contact with the interior of the appliance may present a risk of electric shock!

Any operation in connection with this appliance must be carried out by qualified personnel.

Please note the safety precautions listed in the safety instructions and installation documentation.

Please take note of the safety precautions listed in the operating and installation manuals and other documentation.



Warning

Massive power leakage.

Before connecting the input power, ensure that the earth is securely grounded.

The appliance must be earthed in accordance with local electrical codes.



Warning

When the battery is connected to a bi-directional energy storage converter, DC voltage may be present at the input port. Please take care during operation or check the battery system user manual.



Warning

Do not touch live parts within 5 minutes of power failure!

Dangerous energy is stored in the internal capacitors, so do not touch the terminals, contacts, copper strip, etc. for 5 minutes after disconnecting the appliance from all power sources.



Attention

All internal maintenance and servicing of the equipment should be carried out by trained personnel. Internal components that require the use of tools to open cannot be maintained by the user.

Please read this user manual before operation.

2.3 Additional Information

For further details please click: www.sinexcel.com.

3 Product Introduction

3.1 System Introduction

The Bi-directional Energy Storage Converter is an energy conversion device between the power grid and the battery, capable of charging and discharging the battery. It can invert the direct current (DC) from the battery into alternating current (AC) that can be connected to the power grid, and also rectify the AC from the power grid into DC that can be charged into the battery. The bidirectional energy storage converter can be used in grid-connected mode or off-grid mode.

4*PWS1-135M-R Rack Solution consists of 4*PWS1-135M-R bidirectional energy storage converters, an electrical distribution room and racks.

DC Voltage Input Range:

EX Version: 600-1000Vdc@400Vac (Full load 720-1000Vdc@400Vac) .

3.2 Circuit Schematic

The following is the topology diagram of the 4-module-1-branch (i.e., single-branch) solution:

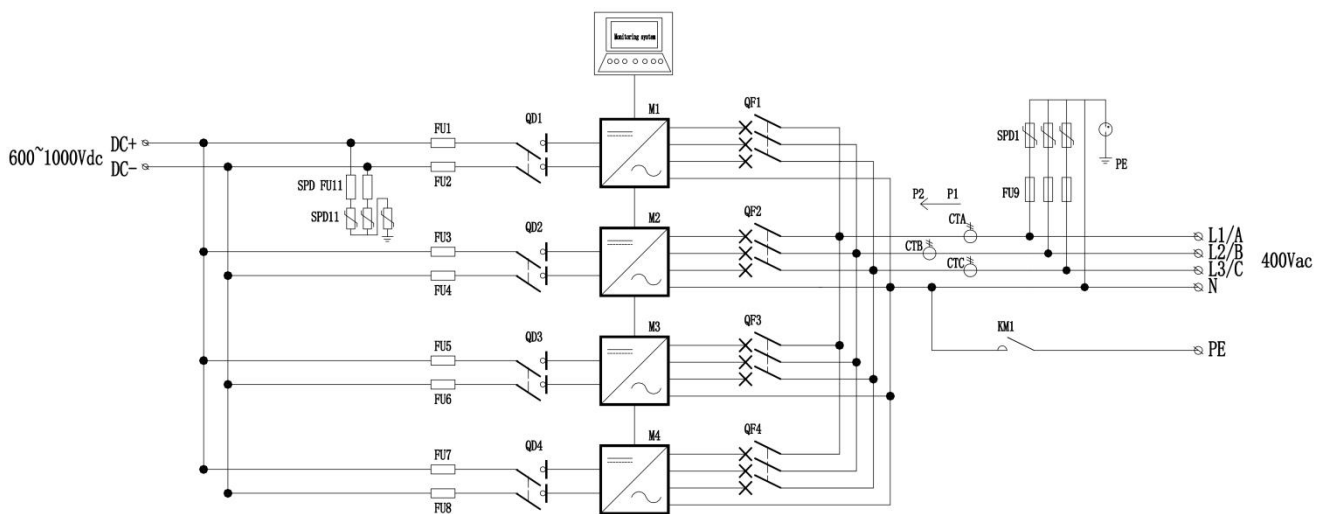

Figure 3.1 Topology Diagram of the 4-module-1-branch (i.e., single-branch) Solution



Attention

The 4-module-1-branch solution consists of 4 AC modules, equipped with 4 DC switches and 4 AC switches.

The composition of the 4*PWS1-135M-R Rack Solution is shown in Table 3-1 below:

No.	Name	Quantity	Remarks
1	Cabinet	1 set	The cabinet is equipped with power distribution components

2	AC/DC Module	4 units	/
3	U2 Control Box	1 unit	Installed on the cabinet

3.3 Equipment Appearance and Layout of Key Components

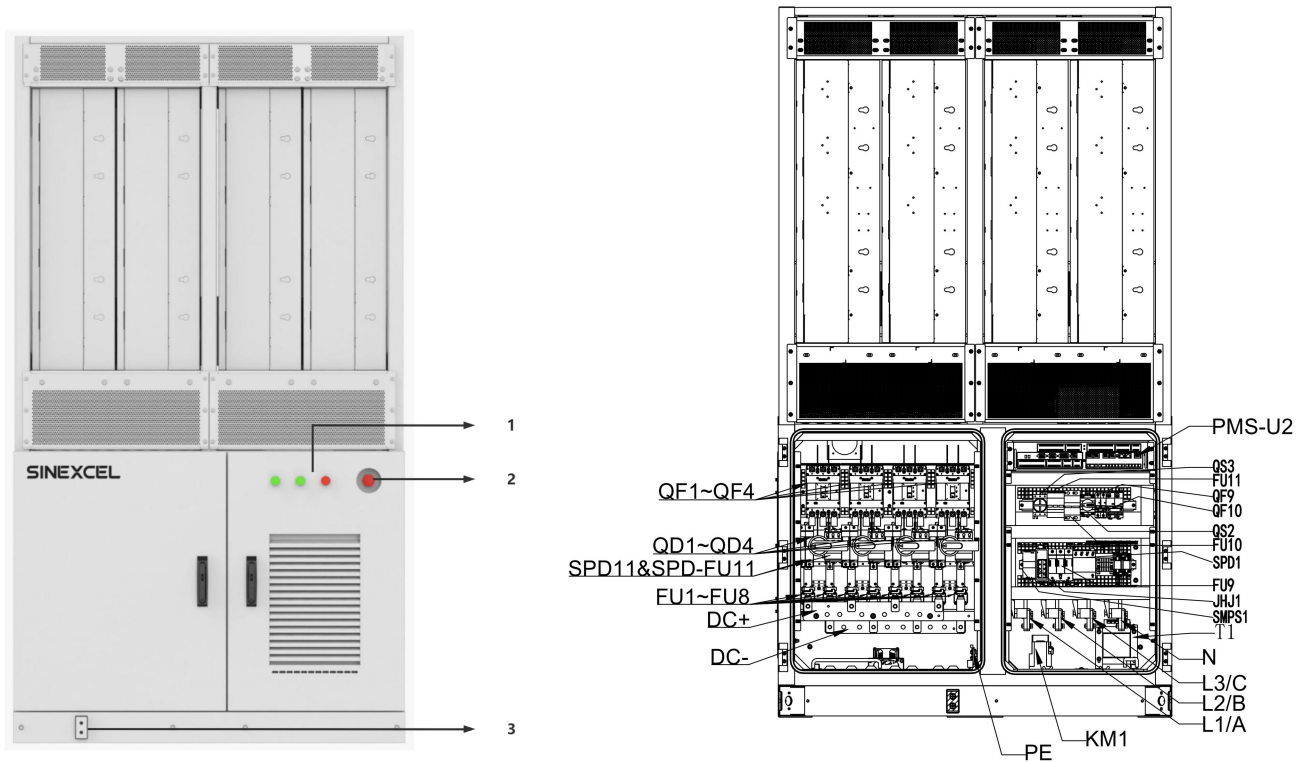

Figure 3.2 Schematic Diagram of Equipment Appearance and Layout of Key Components

No.	Name	Description
1	Indicator Lights	Power: Equipment power indicator light, green Run: Equipment operation status indicator light, green Fault: Equipment fault indicator light, red
2	Emergency Stop Button	
3	Grounding	Cabinet grounding
QF1~QF4	AC Circuit Breaker	
QD1~QD4	DC Isolating Switch	
SPD11&SPD-FU11	Surge Protective Device & Surge Protection Fuse	
FU1~FU8	DC Main Fuse	
PMS-U2	U2 Control Unit	
QS3	AC Isolating Switch	PMS-U2 Power Supply (AC)
FU11	FU11 AC Fuse	
QF9	Miniature Circuit Breaker	Output of Transformer T1
QF10	Miniature Circuit Breaker	Reserved Switch for External DC Auxiliary Power Supply

QS2	DC Isolating Switch	PMS-U2 Power Supply (DC)
FU10	FU10 DC Fuse	
SPD1	AC Surge Protective Device	
FU9	Surge Protection Fuse	
JHJ1	Switch	
SMPS1	Switching Power Supply	24V Power Supply for PMS-U2
T1	Transformer	Auxiliary Power Supply for Rack Internal
N	Power Line	
L3/C		
L2/B		
L1/A		
KM1	PE-N Contactor	Open during Grid-connection, Close during Off-grid
PE	PE Busbar	

3.4 Dimension and Weight

The net weight of the 4*PWS1-135M-R Rack Solution is approximately 1100kg, and the weight with packaging materials is about 1190kg. The actual weight shall prevail. The overall dimensions are 1250mm (Width) * 800mm (Depth) * 2250mm (Height) (Not including screws), as shown in the figure below. In practical applications, attention should be paid to whether the product includes the dimensions of screws or door handles.

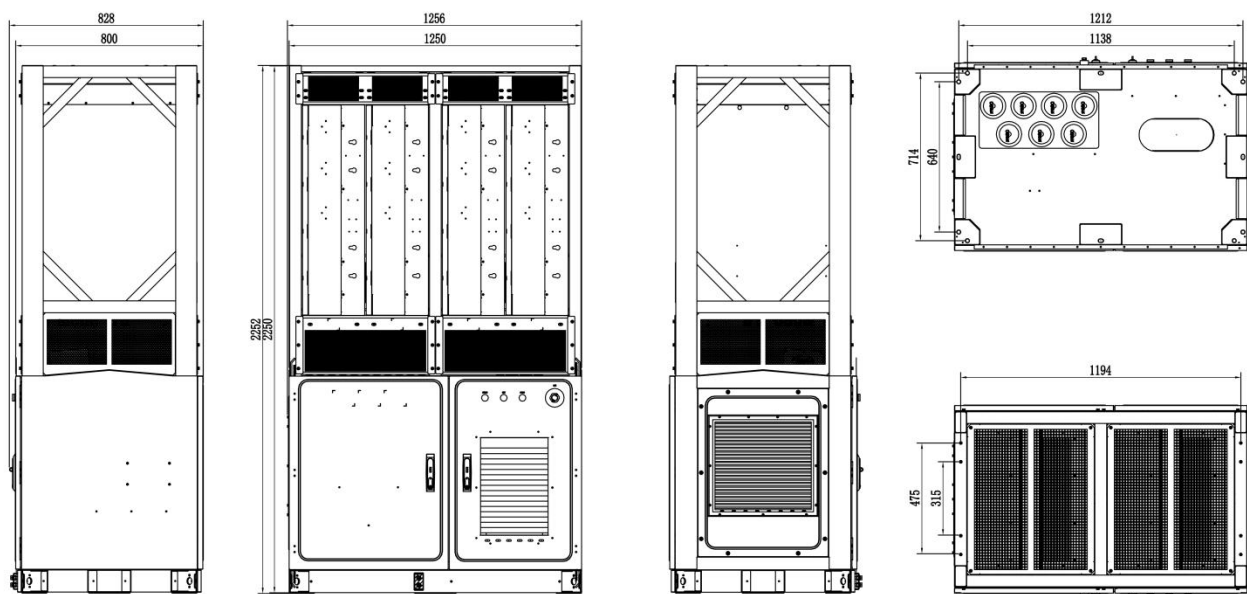

Figure 3.3 Schematic Diagram of Equipment Overall Dimensions

3.5 Heat Dissipation Design

Module Heat Dissipation Design

The protection level of the PWS1-135M-R module is IP66, and the corrosion resistance level is C5. In the rack solution, the module is integrally installed by hoisting, with an air intake and exhaust structure of bottom-in and top-out. Outdoor air enters through the air inlet window on the terminal surface of the module, and hot air is

discharged through the air outlet of the module via the top of the cabinet. The ventilation design is shown in the figure below.

Rack Heat Dissipation Design

The protection level of the 4*PWS1-135M-R Rack Solution is IP55, and the corrosion resistance level of the cabinet is C5. The power distribution part of the rack adopts an integral air intake and exhaust structure of left-in and front-out. Outdoor air enters through the louver on the left side of the rack, and hot air is discharged through the air outlet via the front of the rack. The ventilation design is shown in the figure below.

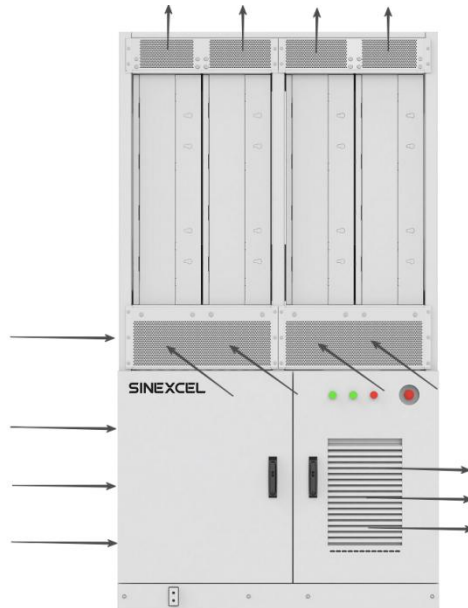

Figure 3.4 Equipment Heat Dissipation Schematic Diagram

3.6 Indicator Light Status of Equipment Inside the Cabinet

3.6.1 Indicator Light Status of PCS

As shown in Figure 3.5 is the schematic diagram of the PWS1-135M-R module control panel (since the module is installed by hoisting, the module indicator lights are located on the terminal surface); the definitions and statuses of the indicator lights are shown in the table below:



Figure 3.5 Schematic Diagram of the Module Control Panel

No.	Name	Description
1	Power	Power indicator light (steady green when powered on)
2	Run	Operation status indicator light (steady green during operation)
3	Fault	Fault indicator light (flashing red for

alarm; steady red for fault)

3.6.2 Indicator Light Status of the U2 Control Box



Figure 3.6 Schematic diagram of the control panel of the U2 control box

No.	Name	Description
1	Power	Power indicator light (steady green when powered on)
2	Run	Operation status indicator light (steady green during operation)

4 Parameters

The following is the technical parameter table of the 4*PWS1-135M-R Rack Solution

Table 4.1 Technical parameters table

Model	Max 4 x PWS1-135M-EX
Utility-interactive Mode	
Nominal Power	4x135kW
AC max power	4*135*1.1kVA
AC Voltage	400 (-15%~15%) Vac
DC Voltage Range	600V~1000V
DC Voltage @full load	720~1000V
DC Current	4x193A
AC Connection	3P3W/3P4W
AC Frequency	50±5Hz
THDi	≤3%
Voltage Ripple Coefficient	≤1%
AC PF	0.99/-1~1
Current Overload	1.1 times long-term
Stand-alone Mode	
Nominal Power	4x135kW
AC max power	4*135*1.1kVA
AC Voltage	400 (-15%~15%) Vac
DC Voltage Range	600V~1000V
DC Voltage @full load	720~1000V
DC Current	4x193A
AC Connection	3P4W
AC Frequency	50±5Hz
AC PF	0.99/-1~1
Current Overload	1.1 times long-term / 1.2 times for 1min / 1.5 times for 10s
System Parameters	
Dimensions (W*H*D)	1250mm*2250mm*800mm (No screws)
	1253 mm*2252 mm*832mm (Including screws and door handles)
Number of Modules	4
DC Input Branches	1 branche
AC Connection	Pre-wired AC common busbar; each PCS AC side is equipped with a circuit breaker
DC Connection	Equipped with a common DC bus for combined connection (each PCS DC side is equipped with a fuse and an isolating switch)
Control System	Integrated PMS-U2 control board for parallel PCS control
Communication Interface	Single Ethernet port for EMS communication; (Equipped with an 8-port switch for communication between the EMS, various modules, and the U2 control box.)
Enclosure	Module: IP66 C5 Rack: IP55 C5 (Enclosure)
Weight	1100kg (Estimated)

Operating Temperature	-40°C~60°C (>55°C derating)
Cooling Method	Air Cooling
Operating Humidity	0~100% (No Condensation)
Operating Altitude	3000m (>3000m Derating)
Installation Method	Floor - standing (No heat source: 1500mm at the front side, 800mm at the left side, and 50mm at the right/rear side)
Communication	
Communication	RS 485, Ethernet, CAN (Through the PMS-U2-P)
Communication Protocol	Modbus TCP/RTU, CAN2.0 (Through the PMS-U2-P)

Application environment restrictions:

Works in stand-alone mode (off-grid mode), there are some restrictions on the application environment.

The parallel connection of multiple bi-directional energy storage converter is a customized function. When users need to connect the AC outputs in parallel in off-grid mode, please contact the manufacturer.



- The load power of resistor < rated power of PCS
- The load power of RCD (resistor - capacitor - diode) < 60% of the apparent power of a single PCS unit. When there are RCD loads, please contact the manufacturer to confirm the PCS capacity configuration.
- For motor loads with frequency converters, the load power < apparent power of a single PCS unit.
- For motor loads without frequency converters, please contact the manufacturer to confirm the PCS capacity configuration. The specific load power of motor that can be carried shall be determined according to the actual on site load conditions, and it is necessary to communicate with our company's technical personnel.
- It is recommended that the maximum load current is less than the rated current of the PCS

5 Storing、Lifting and Transporting

5.1 Transport and Storage

In order to ensure that the energy storage converter is in a better protective state during transportation, please choose to transport with packaging as much as possible, and transport according to the indications of various signs on the packaging. The illustrations of the packaging signs are shown in Table 5-1:

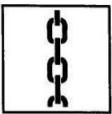
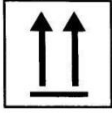
Table 5-1 Description of packaging label

Icon	Description
	Center of gravity mark, indicating the center of gravity of the energy storage converter.
	Lifting mark, indicating the position of the chain or rope when lifting the energy storage converter.
	The upward mark indicates the placement method when carrying and placing the energy storage converter. It is strictly forbidden to put it upside down, horizontally or tilted.
	Handle the logo with care, and avoid violent friction or collision during transportation and placement.
	During transportation and storage, the energy storage converter should be protected from rain or moisture.



NOTICE

Since the center of gravity is not at the mechanical center of the equipment, please pay attention to the center of gravity mark on the packaging box during transportation.



NOTICE

Regardless of whether the converter is packaged or not, it is strictly forbidden to tilt an angle greater than 5° during the movement. Due to its large size and weight, an excessively large inclination angle may cause the equipment to fall upside down, causing casualties or equipment damage.

Please avoid physical shocks to the equipment during the movement, such as suddenly lowering or lifting.



NOTICE

Please avoid transporting the energy storage converter under rain or bad weather conditions. If it is unavoidable, please take necessary protective measures.



NOTICE

The equipment shall not be disassembled during transportation or storage. Equipment failures caused by modifications without the authorization of Sinexcel are not covered by the warranty.



NOTICE

When the equipment is transported and stored, it is strictly forbidden to stack, and no other items are allowed to be stacked on the top of the equipment.



NOTICE

When the equipment is transported and stored, it should be ensured that the environment in which it is located is free of corrosive gas, no high-temperature heat source, not excessively dusty, and meets the fire protection requirements. Storage without packaging is strictly prohibited.

If the on-site installation is not carried out immediately after the completion of the delivery and acceptance work, the energy storage converter with outer packaging should be stored in a ventilated, dry, and clean indoor environment. At the same time, you should also pay attention to the following aspects:

- Restore the package to the state at the time of receipt, and the desiccant in the package must be retained.
- The storage floor is flat and sufficient to carry the weight of the energy storage converter with the outer packaging.
- When storing the equipment, you need to pay attention to ventilation and moisture prevention, and it is strictly forbidden to store water in the storage environment.
- The storage environment temperature is required to be $-40\text{ }^{\circ}\text{C} \sim +70\text{ }^{\circ}\text{C}$, and the relative humidity of the storage environment is required to be 0~100%, without condensation.
- Take care to deal with the harsh surrounding environment, such as sudden cold, sudden heat, collision, etc., to avoid damage to the equipment.
- Regular inspections, at least once a week. Check if the packaging is intact to avoid insect bites. If the outer packaging is damaged, it should be replaced immediately.
- **If the storage time is more than half a year, the package should be opened for inspection, and the desiccant should be replaced and repackaged.**

5.2 Transport

It is recommended to use a forklift to move the equipment with the transportation packaging box in a short

distance without removing the shipping box. When moving, pay attention to the center of gravity mark and lifting mark position on the box, and ensure that the transportation tool has sufficient carrying capacity. Lifting is strictly prohibited.

Moving the energy storage converter without a packaging box is usually used near the installation location of the equipment. It is recommended to use a forklift for operation. When using a forklift, the bottom baffle of the equipment needs to be removed first.

1) Forklift movement (preferred)

Using a forklift to transport the energy storage converter is a standard way of movement. The center of gravity of the converter should fall between the two forks of the forklift and be pre-inserted to ensure that it will not tilt after being lifted. As shown in the figure below, the length of forklift forks shall not be less than 1.3m.

In the process of using a forklift to fork, lower and move the energy storage converter, it is necessary to ensure that it is slow and stable, and the energy storage converter must be placed on a firm and level ground.

In the entire process of using a forklift to operate, it is necessary to strictly abide by the forklift safety operation specifications. Due to the large volume of the energy storage converter, it may obstruct the driver's sight, so assistance should be provided for cooperation.



Figure 5.1 Schematic Diagram of Forklift

2) Pallet truck movement

The use of a pallet truck to move the equipment is only suitable for conditions where the transportation route is relatively stable. During transportation, the center of gravity of the converter should fall between the two forks of the forklift and be pre-inserted to ensure that it will not tilt after being lifted. As shown in the figure below, the length of the forklift forks shall not be less than 1.3m, the inner distance between the two fork arms of the pallet truck shall not be less than 0.3m, the outer distance shall not be greater than 0.75m, and the load-bearing capacity of the pallet truck

must be $\geq 1500\text{kg}$.

In the process of using a forklift to fork, lower and move the energy storage converter, it is necessary to ensure that it is slow and stable, and the energy storage converter must be placed on a firm and level ground.

In the entire process of using a forklift to operate, the relevant safety operation regulations must be strictly observed. Due to the large size of the energy storage converter, it may obstruct the operator's view, so assistance should be provided for cooperation.

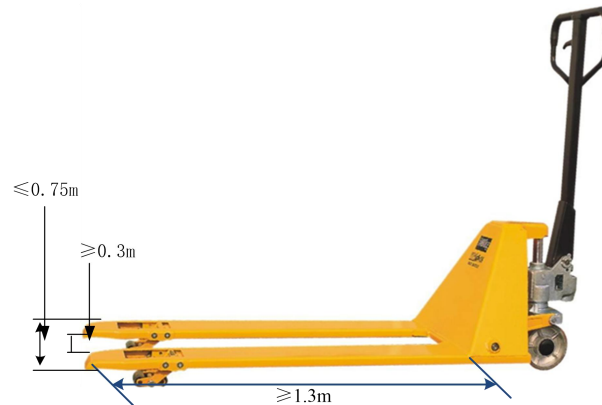

Figure 5.2 Schematic Diagram of Pallet Truck



NOTICE

Before moving with a forklift or pallet truck, the bottom baffle of the energy storage converter must be removed, otherwise the bottom baffle will be damaged.



NOTICE

No matter which way you choose to move the energy storage inverter, you must ensure:

- Must always pay attention to the position of the center of gravity.
- Must be considered the volume and weight at all times.
- Must be ensured the safety of operators at all times.

Take necessary auxiliary measures to ensure that the equipment is transported to the installation site in good condition.

5.3 Unpacking Inspection

5.3.1 Unpacking

When the equipment is transported to the vicinity of the installation site, the transport box needs to be removed.

The removal steps are as follows:

- ① Remove the top panel of the box.
- ② Remove the wooden side panel of the packing box.
- ③ Remove the shielding material from the packing box.
- ④ Remove the anchor parts that fix the energy storage converter on the transport wooden bracket.



NOTICE

After removing the anchor parts between the energy storage converter and the transport wooden bracket, it is strictly forbidden to transport the equipment through the wooden bracket.

5.3.2 Inspection

Before leaving the factory, the equipment has been checked by the staff of Sinexcel and packed firmly. Nonetheless, the following items need to be checked after the energy storage converter shipping packaging has been removed:

Check whether the quantity of each item on the packing list is consistent with the actual item;

Check whether the nameplate data of the product is consistent with the order contract, such as product model, rated capacity, voltage level, etc.;

Check whether the factory documents and accessories are complete;

Check whether the appearance of the energy storage converter is consistent with the description in this manual;

Check the energy storage converter for deformation, peeling paint and loose parts.

The packing list of the 4*PWS1-135M-R Rack Solution is shown in the table below.

Table 5.2 Packing List

No.	Name	Quantity
1	Equipment (including cabinet door keys and related accessories)	1 unit
2	Equipment delivery drawings (including primary circuit diagram and communication wiring diagram)	1 copy
3	Product certificate of conformity / Warranty card	1 copy
4	Factory test report	1 copy



NOTICE

Installation and debugging can only be carried out on the equipment that has been inspected correctly and is complete without damage. During the inspection process, if any problem is found, please contact the transporter or Sinexcel in time.

6 Equipment Installation

6.1 Installation Process

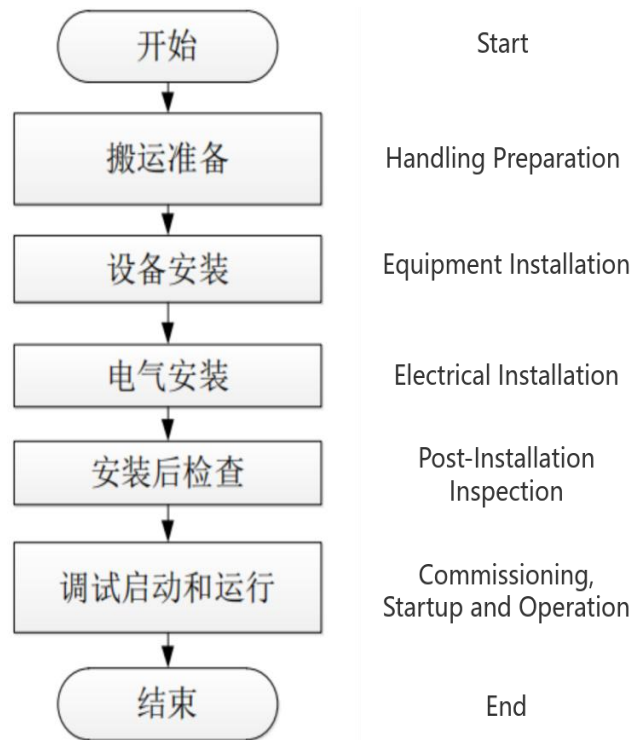

Figure 6.1 Installation process

6.2 Installation Notes



Danger

The live parts of the equipment are high voltage and touching them may result in death or serious injury from electric shock.

Please wear appropriate personal protective equipment for work.

Do not touch any live parts.

Observe all warnings that appear on the equipment and in the documentation.

Follow all safety information provided by the battery manufacturer.



Danger

Touching the DC cables may cause a risk of electric shock.

The DC cable connected to the battery is live. Contact with live cables may result in death by electric shock or serious injury. Before connecting the DC cable, make sure that there is no voltage on the DC cable.

Please wear appropriate personal protective equipment for work.



Warning

Insulation damage in the storage system can cause fatal ground currents that can result in electric shock. Ensure that the insulation resistance of the storage system exceeds the minimum value.

Insulation resistance minimum: $1\text{M}\Omega$.

The bi-directional storage converter must be installed in a closed electrical operating area.



Warning

Failure to adhere to torque specifications when bolting can cause fires.

Failure to comply with the specified torque will reduce the load-bearing capacity of the bolted connection and thus increase the contact resistance value.

May cause local overheating and fire.

Make sure to always tighten the bolted connections using the torque specified in this document.

When working on equipment, use only the correct tools.

Avoid repeatedly tightening the bolts as this may result in unacceptably high torques.

6.3 Equipment Installation

6.3.1 Basic Requirements

The protection level of the 4*PWS1-135M-R Rack Solution is IP55, and the corrosion resistance level of the cabinet is C5 (the PWS1-135M-R module has a protection level of IP66 and a corrosion resistance level of C5), so it can be installed outdoors. Since the equipment generates noise during operation, it is recommended to install it away from residential areas, and the installation location should be free of corrosive and flammable gases.

To ensure that the equipment can operate safely and efficiently, it is important to observe the following when selecting the installation environment:

- The equipment must be mounted on a suitable concrete support with a refractory surface, and the converter inlet and outlet must not be obscured.
- The installation ground is dry and flat, no water accumulation, the ground level does not shake, and it can completely carry the weight of the equipment.
- Installation site ambient temperature range: $-40\text{ }^{\circ}\text{C} \sim +60\text{ }^{\circ}\text{C}$; relative humidity range: 0~100%, non-condensing.
- Equipment Grounding Resistance $\leq 4\ \Omega$.

- Cabinet should be installed in a location that ensures easy viewing of the LED indicators.
- If the equipment is placed directly outdoors, it is recommended to take the necessary shading measures for the machine to avoid the machine temperature rising due to direct sunlight, causing the machine to run at reduced capacity.

6.3.2 Outdoor Requirements

Equipment is capable of operating within an ambient temperature of $-20\text{ }^{\circ}\text{C} \sim +60\text{ }^{\circ}\text{C}$. When the ambient temperature is higher than $55\text{ }^{\circ}\text{C}$ the machine will run at a decreased rate.

The sunlight irradiation intensity should be $\leq 1200\text{W/m}^2$, and it is recommended that the inverter installed outdoors should take the necessary shading measures.

6.3.3 Foundation support requirements

The equipment shall be installed on a structure supported by a cement foundation or steel channel with a flame-retardant surface. The foundation must be flat, solid, safe and reliable, and have sufficient bearing capacity. Installation on a foundation with depressions or inclinations on the surface is strictly prohibited.

When constructing the foundation, cable trenches shall be preset according to the overall design of the power station and the cable inlet and outlet positions at the bottom of the equipment.

Pre-drilled holes are required on the foundation, and the size of the holes must be completely consistent with the positioning holes of the equipment base to firmly connect the equipment to the foundation.

As shown in the figure below, the equipment of the 4*PWS1-135M-R Rack Solution is equipped with 12 positioning slotted holes of $12\text{mm} \times 35\text{mm}$. It is recommended to use 8.8-grade M12*35 bolts to fasten the equipment base to the foundation.

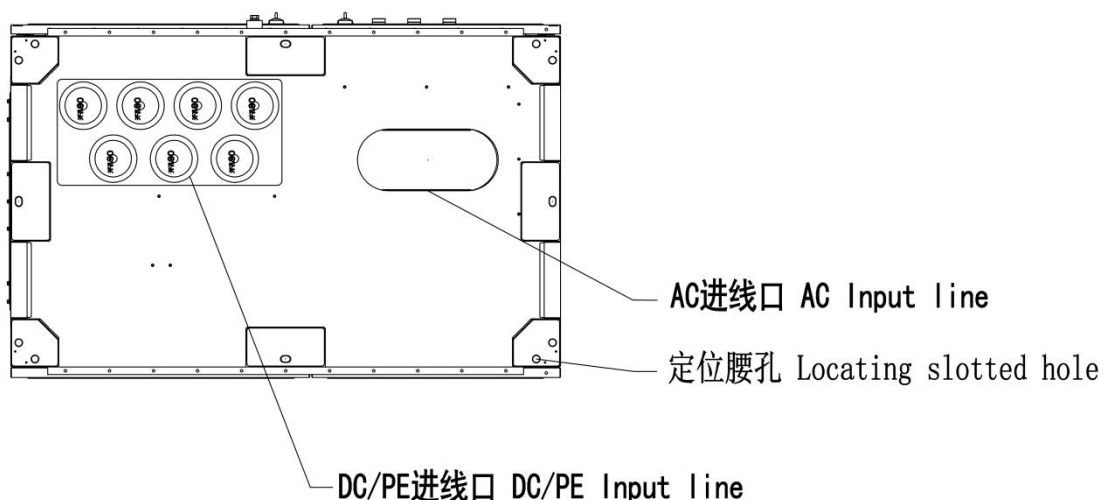

Figure 6.2 Equipment Bottom View

6.3.4 Space requirement

As shown in the figure below, during equipment installation, sufficient distance must be maintained between the equipment and walls, box walls as well as other equipment to meet the requirements for the narrowest maintenance aisle, evacuation route and ventilation. The requirements in this section are the minimum space requirements for the normal operation of the energy storage converter. If on-site conditions permit, it is recommended to select a larger spacing to ensure the reliable and efficient operation of the equipment.

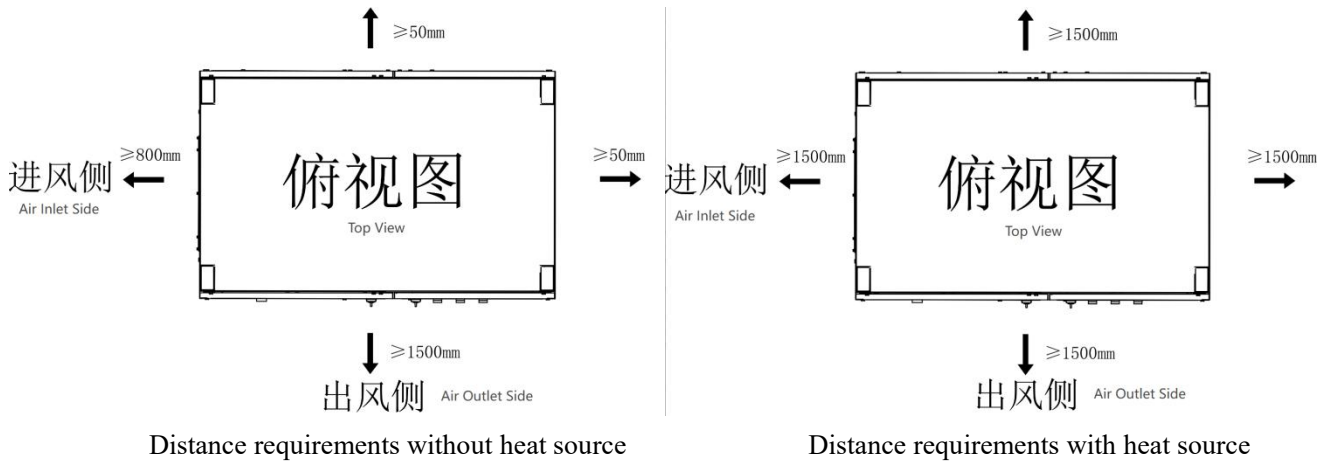

Figure 6.3 Equipment distance requirements

Note:

- 1) When the air outlet of another device directly faces this device's outlet, the distance must be extended to 3500mm.
- 2) The top distance from the air outlet surface of the PWS1-135M-R module should be 250mm.

6.3.5 Ventilation Requirements

The equipment will generate a lot of heat when running, and the high temperature will directly affect the electrical performance of the equipment and even damage the equipment, so the ventilation and heat dissipation needs of the equipment should be fully considered when planning the installation environment of the converter to ensure the normal and efficient operation of the equipment.

To ensure the reliable and efficient operation of the equipment, please regularly clean the grille, filter and filter cotton of the air inlet and outlet of the equipment, and regularly check whether the equipment exhaust fan is functional.

In order to meet the ventilation requirements of the equipment, its installation environment needs to meet the following requirements:

- 1) The equipment should be avoided to be installed in poor ventilation conditions and low air flow.
- 2) The air inlet should have sufficient fresh air supply.

- 3) Air quality must be ensured. If the air contains too much sand, dust and other suspended matter, the air purity can be improved by installing filters at the air supply grille and other measures.
- 4) The ventilation system of the energy storage cabinet must be independent of the ventilation system of other equipment and do not affect each other.

If a heat dissipation air duct needs to be installed, the air duct shall be designed by professionals in advance to avoid air backflow in the energy storage converter cabinet. Meanwhile, all joints must be sealed to prevent air leakage, and the selected sealing material shall have a temperature resistance of at least 80°C. After the installation of the heat dissipation air duct, the interior of the energy storage converter shall be inspected to prevent sundries such as screws and gaskets from falling into the cabinet during installation.

6.3.6 Other requirements

After wiring, seal the cable entry and exit holes with fireproof mud to prevent rodent damage. The equipment list does not include fireproof mud.

6.4 Site Installation

6.4.1 Wire Channel Design

The equipment employs a bottom-in, bottom-out wiring configuration. For easier installation and maintenance, all external cables should be routed through a dedicated cable trench. A concrete cable trench must be pre-installed beneath the equipment foundation, or rigid supports should be installed to elevate the mounting surface, with cables laid overhead. If a cable trench is pre-installed, the equipment can be secured using anchor bolts or channel steel. When steel supports are used, the equipment can be directly mounted and fixed to them.

The cable trench is usually designed and constructed in accordance with the relevant standards, considering the weight of the required cables and the space.

The cross section of the trench is shown in Fig. 6-3. The quantities of cable brackets refers to the user's demands. In order to facilitate the installation and maintenance, the DC circuit and AC circuit should be laid separately.

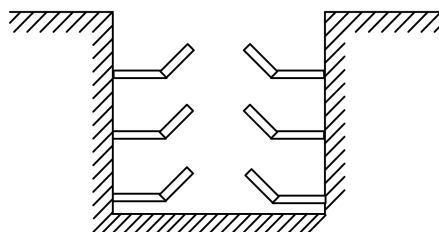

Figure 6.4 Cross-sectional view of the gutter

6.4.2 Equipment securing

When mounting the equipment on channel steel, ensure the cable trench installation and channel steel openings meet the equipment's installation requirements prior to final fixation. For concrete surface mounting, drill holes and secure the equipment with expansion bolts.

The equipment mounting method is illustrated in the diagram below.

- 1) To secure the device, follow these steps: Use the appropriate tool to transport the device to the installation location and align it with the mounting hole.
- 2) The equipment is fixed to the channel steel or foundation by M12*35 bolts through the base waist hole.
- 3) Install the base plate to secure the equipment.



(a) Schematic diagram of the equipment fixed to the channel (b) Schematic diagram of the equipment fixed to the ground

Figure 6.5: Method of equipment fixation

6.5 Electrical Connection

6.5.1 General Safety Rules



Danger

Danger of electric shock!

Please make sure that the installation cables and equipment are not charged before installation.

The capacitor inside the equipment is a hazardous energy storage device, do not place flammable and explosive substances near the equipment.



Warning

All electrical connections must comply with the electrical connection standards of the country where the project

is located.

Equipment should only be connected to DC with the permission of the local power company and only after installation by a qualified technician.



Warning

Only a qualified electrician or a qualified person should make the electrical connections to this product. Please strictly follow the wiring signs inside the equipment.

The following safety rules must be observed throughout the electrical connection of the equipment and during subsequent maintenance and repair operations:

- Disconnect all external connections to the equipment and to the internal power supply of the device.
- Ensure that the equipment is not accidentally re-powered.
- Use a multimeter to make sure that the inside of the equipment is completely de-energized.
- Apply the necessary ground connections.
- Insulate and cover the adjacent potentially energized parts of the operating section with a fabric made of insulating material.

6.5.2 Installation Tools

The following tools are required prior to installation:

- Torque wrench
- Screwdriver
- Wire stripper
- Terminal crimping machine
- Hot air gun (or hot air blower)
- Multimeter

6.5.3 Wiring Parts

The parts such as fixing screws for the power cable connection of the equipment have been packed in a uniform bag when the equipment is delivered, so please connect the cables in strict accordance with the screw fastening rules.



Attention

When connecting the cables, make sure that the connectors are tightened.

Inadequate connection or oxidation of the contact surface may cause local heat accumulation, which may lead to

fire and combustion.



Attention

When wiring the power line, use copper wire of appropriate size and use copper terminals to fix it tightly before connecting it to the wiring copper strip.

6.5.4 Preparation before Wiring

- 1) Open the front cover or front door of the equipment

Before connecting the user, open the front lower cover plate or front door of the device.

- 2) Open the inlet hole

The equipment features a bottom-entry and bottom-exit design, with dedicated wiring holes at the base for external connections. To prevent foreign objects from entering during transportation, the delivered unit includes a protective cover for the wiring holes, which must be removed before wiring.

6.5.5 Wiring methods and cable requirements

The device employs a bottom-in bottom-out wiring configuration, with cables routed vertically through the base's cable pass-through holes into the cable trench. By opening the front door and removing the door panel, the wiring busbar becomes visible. For cable connections, select single or multiple cables with appropriate diameters, preferably those with a current rating of $\leq 3A$ per $1mm^2$ conductor.

The wiring method should comply with the national electrical regulations or other local standards.

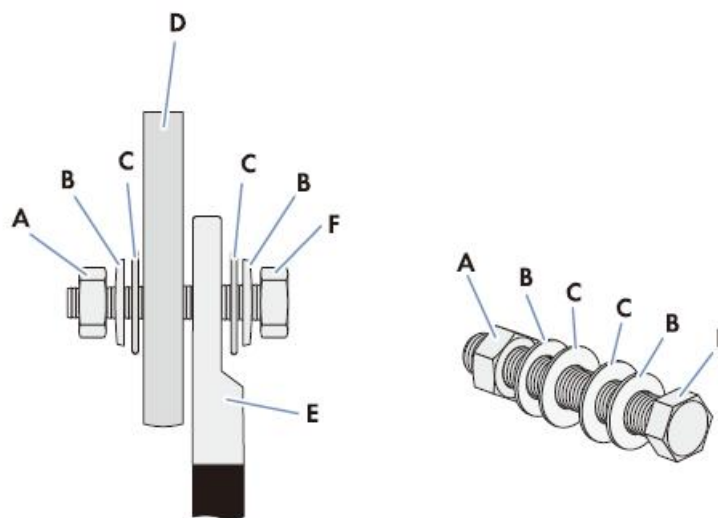

Figure 6.6 Wiring Method

No.	Description
A	M12 nut

B	Spring Washer
C	Flat Washer
D	Connecting Busbar
E	Copper Lug Terminal
F	M12 bolt

The cable selection requirements are as follows:

- The selected cable must have sufficient current-carrying capacity. The current-carrying capacity of the conductor is related to the environmental conditions, the type of conductor insulation material, the laying method, the wire material and the cross-sectional area.
- All cables must be sized to accommodate the maximum current on either side of the energy storage converter, with a safety margin.
- The connecting wires on the same side should be of the same specification and type.
- Select flame-retardant cables.

The recommended wire diameter for connecting cables is shown in the table below.

Cable	Wire Diameter Requirement	Mounting Bolt Specification
Battery-side DC+	1 piece of 70mm ² recommended per PWS1-135M-R module	M12
Battery-side DC-	1 piece of 70mm ² recommended per PWS1-135M-R module	M12
AC-side L1/Phase A	3 pieces of 95mm ² recommended per phase	M12
AC-side L2/Phase B		M12
AC-side L3/Phase C		M12
AC-side Neutral (N)		M12
Ground Wire	2 pieces of 70mm ² recommended	M12
Communication Cable	Shielded cable recommended (485, CAN communication: 2*0.75mm ²)	-



Attention

It is strictly forbidden to overload the cable, and the current distributed on the 1mm² cable is strictly forbidden to exceed 3A.



Attention

For on-site wiring, derating verification of current-carrying capacity and temperature shall be performed according to the actual operating conditions. The above cable recommendations are based on an ideal scenario (a single cable installed in air) without interference from other heat-generating cables.

It is recommended that the selected cables meet the following requirements: the rated voltage of AC cables shall be $\geq 600\text{V}$; the rated voltage of DC cables shall be $\geq 1000\text{V}$; the rated temperature of the insulation sheath shall be not less than 105°C .

6.5.6 Precautions for wiring



Attention

Before all electrical wiring is performed, all connecting cables must be insulated and inspected for completeness. Use of poorly insulated, partially exposed or otherwise damaged cables is strictly prohibited.



Attention

Before wiring, make sure that the polarity of either side of the cable is correct.

During wiring, do not pull on the cable to avoid damaging its insulation properties.

All cables need to maintain an adequate bend radius.

Take the necessary auxiliary measures to reduce the stress on the cable.

The length of the screws should be selected appropriately; screws that are too long may affect the insulation performance of the equipment.

Installation should prevent part of the heat-shrinkable sleeve from being sandwiched between the copper nose and the copper row, otherwise it may lead to poor contact and even damage the equipment.

After each step of the wiring operation, it should be carefully checked to ensure that the wiring is correct and firm.



Attention

Incorrect wiring may cause fire and combustion, so please pay attention to the connection order of wiring components.

When connecting, make sure that the connections are tight. Inadequate connection or oxidation of the contact surface may cause local heat accumulation and may lead to fire and combustion.



Attention

After all the electrical connections are completed, the wiring should be fully checked to confirm that it is correct, and then use fireproof mud to seal the gap at the entrance of the wire to prevent small animals from entering.

6.5.7 Wiring Area Overview

The 4*PWS1-135M-R rack solution features all device input/output terminals at the cabinet base, as shown in the diagram. Connect the wiring according to the markings.

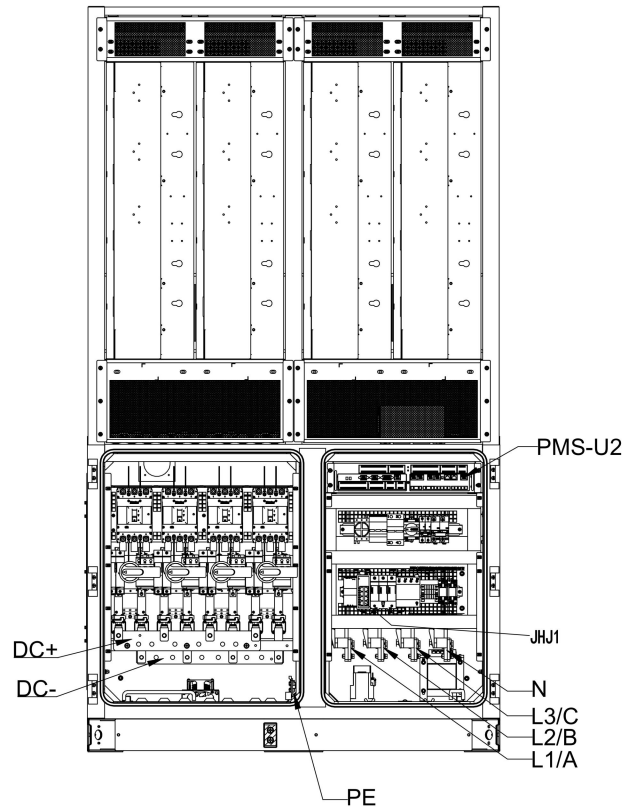

Figure 6.7 Equipment terminal layout diagram for the 4-module-1-branch solution

6.5.8 DC Side Wiring

Before wiring the DC side, the following check should be performed:

- Measure the open-circuit voltage of the battery/busbar set to ensure that the open-circuit voltage is within the normal DC voltage range of the energy storage converter.
- Confirm the positive and negative polarity of the cable and mark it well.



Attention

The open circuit voltage of the battery pack is strictly prohibited to exceed the maximum DC input voltage of the energy storage converter, too high open circuit voltage will cause damage to the energy storage converter. The positive and negative terminals of the battery pack are connected to the positive and negative copper row of the energy storage converter, not to be reversed.

To connect either side of the cable, proceed as follows:

- ① Make sure that the battery or bus bar of the front stage of the energy storage converter is disconnected.

- ② Confirm that the DC disconnect switch or DC circuit breaker of the energy storage converter is open.
- ③ Peel off the insulation skin at the end of the cable, the length of the bare cable should be more than the wiring copper nose wire hole depth of about 5 mm.
- ④ Use terminal crimping machine or crimping pliers to compress the wiring copper nose.
- ⑤ Select heat shrink tubing that matches the size of the cable and use a hot air blower to shrink the tubing.
- ⑥ Fasten the DC+ and DC- cables respectively with the appropriate size bolts using a wrench.

In order to prevent the wiring copper nose loosening caused by poor contact, or to increase the contact resistance caused by local overheating or even fire, should ensure that the tightening screw to meet the torque requirements shown in Table below:

Screw size and torque comparison table

Screw size	M6	M8	M10	M12	M16
Torque(N.m)	7~8	17~20	34~40	60~70	119~140



Danger

Disconnect the DC distribution isolator switch to ensure there is no dangerous voltage in the system during wiring.



Attention

The battery's voltage polarity must not be reversed; always check with a multimeter before wiring.

6.5.9 AC Side Wiring

Before wiring the AC side, the following checks should be performed:

- Measure the AC line voltage to ensure that the AC line voltage is within the normal AC voltage range of the energy storage converter.
- Confirm the phase sequence of the cable and mark it well.



Attention

Incorrect AC side wiring can cause the energy storage converter to not work properly or even be damaged.

Make sure the grid-side distribution circuit breaker is disconnected and the AC and DC disconnect switches are disconnected before wiring.

If there is an "N" line tap on the machine side of the isolation transformer, the "N" line is suspended and must be well insulated, and it is forbidden to ground the "N" line.

The AC side of the equipment must be connected to the power grid via an isolation transformer. The copper busbar connection on the AC side is performed as follows:

- ① Check that the power distribution switch of the AC side of the equipment is in the open state.
- ② Check that the AC and DC circuit breakers are in the open position.
- ③ Select bolts of appropriate size and tighten the copper bars of phases "L1/A", "L2/B", "L3/C" and "N" with wrenches.
- ④ Check that the wiring is secure.



Danger

When wiring, ensure there is no dangerous voltage at the connection points.



Attention

Connect all wiring externally through the terminal holes at the bottom of the device. After completing the wiring, seal the holes with fireproof sealant.

6.5.10 System Grounding



Attention

The grounding cable must be well grounded, otherwise:

- Possible fatal click hazard to the operator in case of failure.
 - Possible equipment damage in the event of a lightning strike.
 - May cause the device to fail to operate properly.
-

Before equipment delivery, both the casing and all grounded components must be securely connected to the grounding busbar at the machine base. During installation, the PE grounding busbar should be reliably linked to the site's ground or the equipment room's equipotential bonding device via a grounding cable. This connection must then be further connected to the earth or grounding grid through the bonding device, with the grounding resistance not exceeding 4Ω.

Cable and terminal specifications:

- Grounding cables: It is recommended to use two outdoor copper-core cables with a cross-sectional area of at least 70mm² (2/0AWG).
- Copper Lug terminal: M12.

Connection procedure:

Step 1: Use a wire stripper to remove the insulation from the grounding cable to the required length.

Step 2: Insert the bare core into the conductor crimping zone of the OT terminal and secure it with a hydraulic clamp.

Step 3: Attach the terminal to the grounding bolt and tighten it.

After completing the cable connection, seal the gaps around the equipment base with fireproof mortar. Tighten the waterproof terminals of communication cables, and cover unused terminals with appropriate plugs to ensure waterproof and dustproof performance.

6.5.11 Communication Interface

The 4*PWS1-135M-R Rack Solution features a switch configured for incoming communication between the EMS and the device's U2 control box. The schematic diagram shows the specific location and port arrangement, while the terminal block layout and wiring diagram are illustrated below.

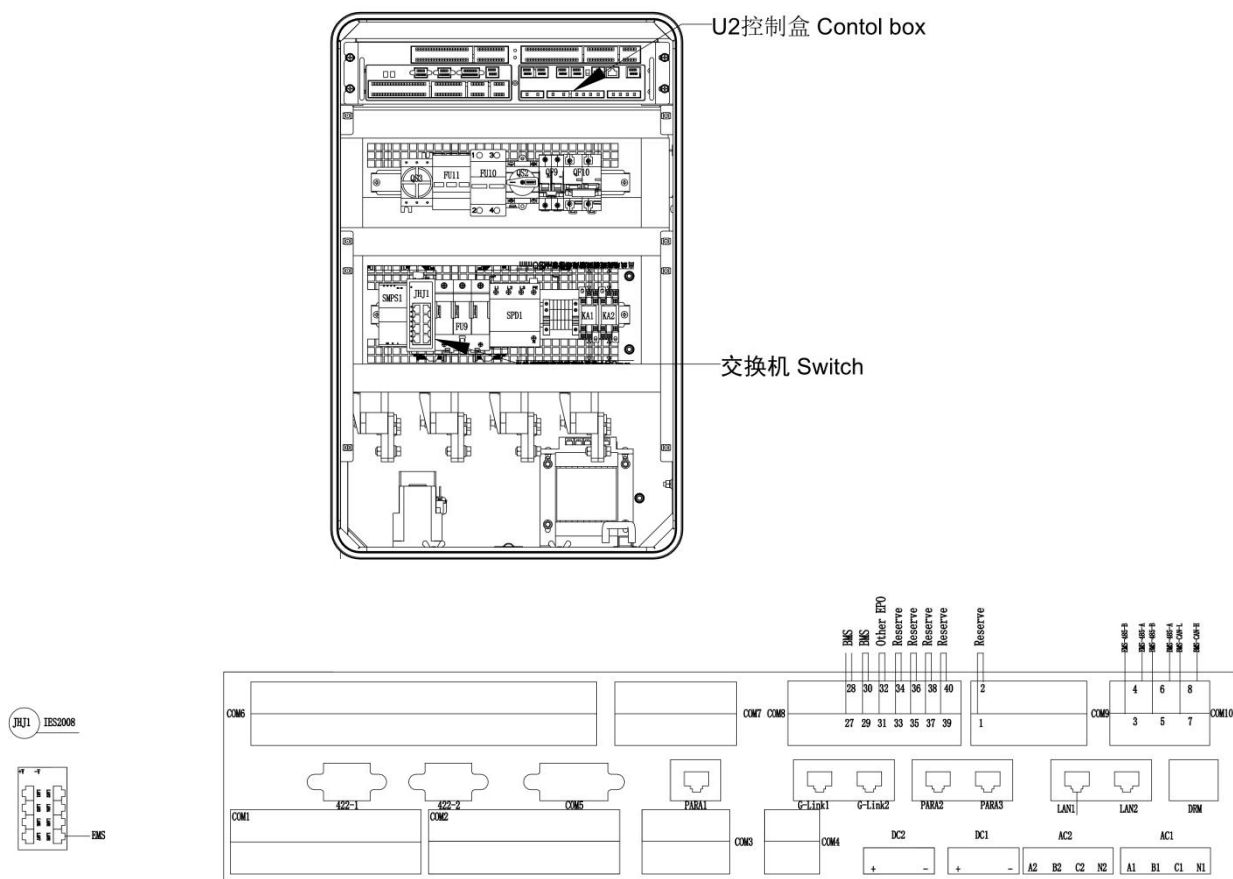

Figure 6.8 Diagram of communication equipment, bit machine, and wiring

As shown in the figure above, the terminal block is equipped with communication points for user access.

Interface Location	Dry Contact Definition	Description
U2-COM8	27: GND_SELV 28: DI_EXT_IN1	27/28: BMS Fault Dry Contact (Normally Open) Alarm and Shutdown

	29: GND_SELV	29/30: BMS Fault Dry Contact (Normally Closed)
	30: DI_EXT_IN2	Alarm and Shutdown
	31: GND_SELV	31/32: EPO Fault Dry Contact (Normally Closed)
	32: DI_EXT_IN3	Alarm and Shutdown
	33: GND_SELV	33/34: Reserved Dry Contact (Normally Closed)
	34: DI_EXT_IN4	Alarm and Shutdown
	35: GND_SELV	35/36: Reserved Dry Contact (Normally Closed)
	36: DI_EXT_IN5	Alarm and Shutdown
	37: GND_SELV	37/38: Reserved Dry Contact (Normally Closed)
	38: DI_EXT_IN6	Alarm and Shutdown
	39: GND_SELV	39/40: Reserved Dry Contact (Normally Closed)
	40: DI_EXT_IN7	Alarm and Shutdown
U2-COM9	1: GND_SELV	1/2: Reserved Dry Contact (Normally Closed)
	2: DI_EXT_IN8	Alarm and Shutdown
U2-COM10	3: EMS-485-B	3/4: EMS Communication Dry Contacts
	4: EMS-485-A	
	5: BMS-485-B	5/6: BMS Communication Dry Contacts
	6: BMS-485-A	
	7: BMS-CAN-L	7/8: BMS CAN Communication
	8: BMS-CAN-H	

6.5.12 Installation Checklist

After the device is installed, at least two staff members must conduct a comprehensive inspection according to the following methods and items listed in the table below. Records must be kept during the inspection, and any non-compliant items should be corrected immediately.

- 1) The equipment should be placed and installed reasonably to meet the safety distance requirements.
- 2) The wiring is correct. The ground wire is well connected to the ground grid. Ask the technician to check the ground resistance.
- 3) Compare the factory main wiring diagram with the on-site wiring diagram. Check if there are any differences and determine whether they will affect the safe operation of the energy storage system.

Installation Checklist

Mechanical installation inspection	
<input type="checkbox"/>	No deformation or damage to PCS
<input type="checkbox"/>	PCS bottom fixed, stable and reliable support
<input type="checkbox"/>	Sufficient space around PCS
<input type="checkbox"/>	The temperature, humidity and ventilation of the environment in which PCS is located meet the requirements
<input type="checkbox"/>	Smooth cooling air circulation
<input type="checkbox"/>	Complete and reliable cabinet sealing protection

Electrical installation inspection	
<input type="checkbox"/>	PCS grounding is complete and solid
<input type="checkbox"/>	Grid-side voltage matches PCS AC-side voltage
<input type="checkbox"/>	The net side connection phase sequence is consistent, the tightening torque meets the requirements
<input type="checkbox"/>	Battery system DC voltage matched to PCS DC side voltage
<input type="checkbox"/>	DC positive and negative polarity matched with PCS positive and negative polarity
<input type="checkbox"/>	Communication wiring is correct, and keep a certain distance from other cables
<input type="checkbox"/>	Correct and clear cable marking
<input type="checkbox"/>	Complete and reliable insulation shield, clear and firm hazard warning labels
Other inspection	
<input type="checkbox"/>	All useless conductive parts are tied with insulating ties
<input type="checkbox"/>	No tools, parts, iron filings or other foreign objects left inside the cabinet
<input type="checkbox"/>	No condensation of moisture or icing inside the cabinet

7 Operation and Debugging

7.1 Control Method

7.1.1 Ethernet Connection

Use Ethernet connection. First, open a browser on the computer desktop, ensure that the laptop and the device are on the same network segment, and that the laptop's network port is reliably connected to the device's network port 1 or 2. The default IP for U2 monitoring ports 1-2 is 192.168.x.136. Then, enter the machine's default IP(192.168.x.136 in the browser's address bar, and the login interface as shown in Figure 7.1 will appear.

Enter 'user' in the Username field and the initial password '080808' in the Password field. Click 'Login' to access the backend interface of the PMS-U2 control box, as shown in Figure 7.1.

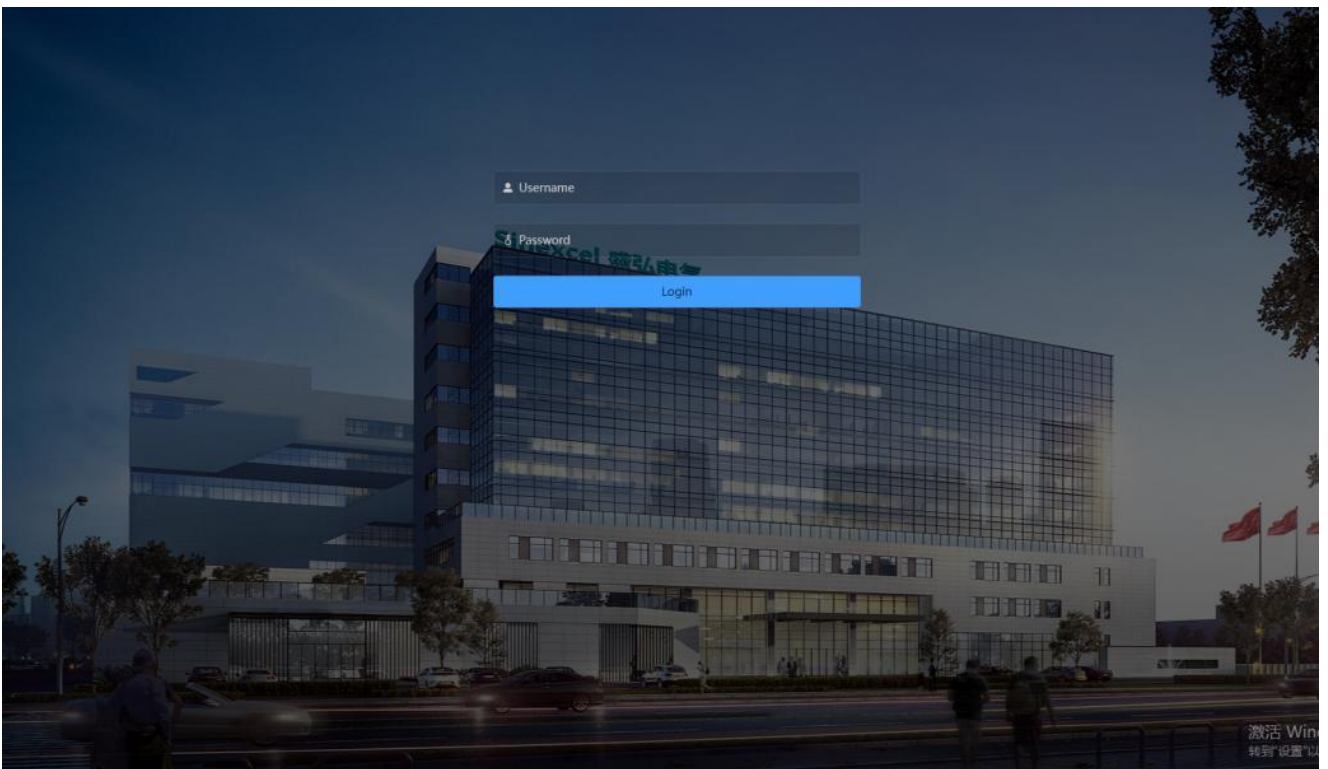

Figure 7.1 Login interface

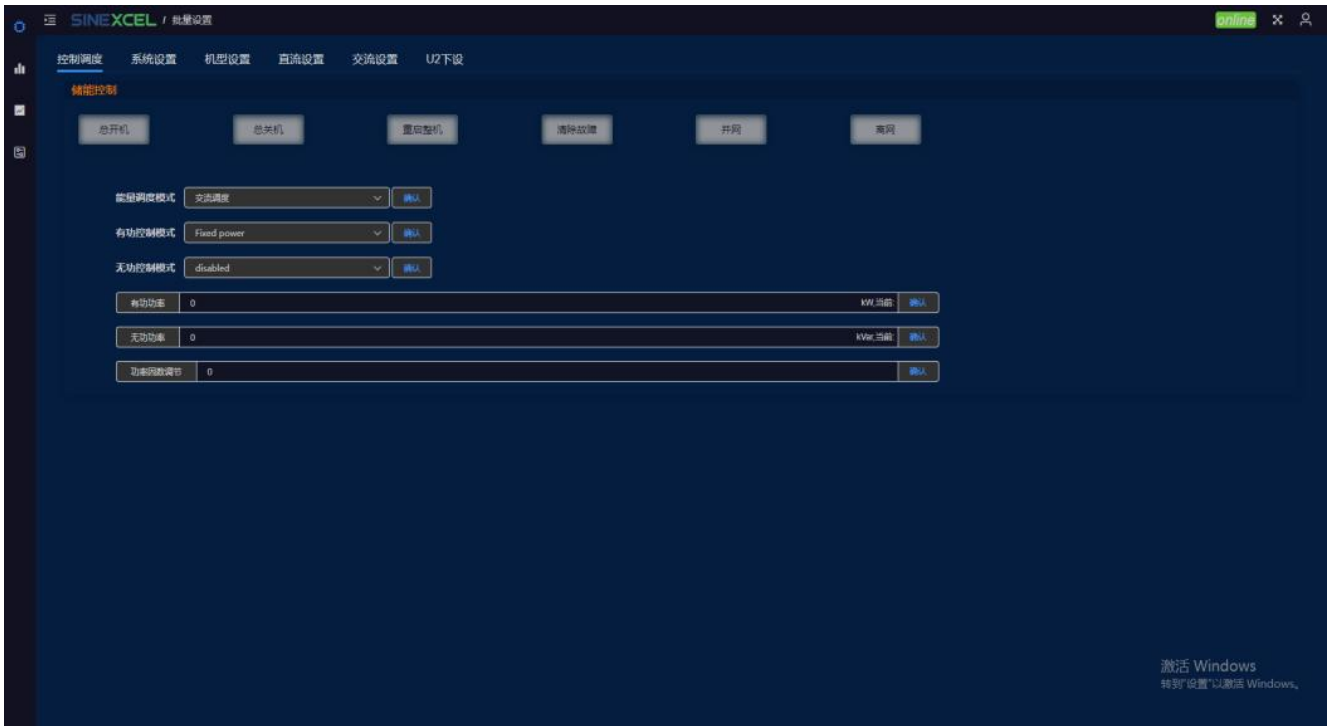

Figure 7.2 Example of the web backend interface

7.1.2 IP Settings

To modify in Tools---Other, click the modification in Figure 7.3 and enter password 123456 to change the IP address. Note: The modified IP addresses for two network ports cannot be in the same network segment

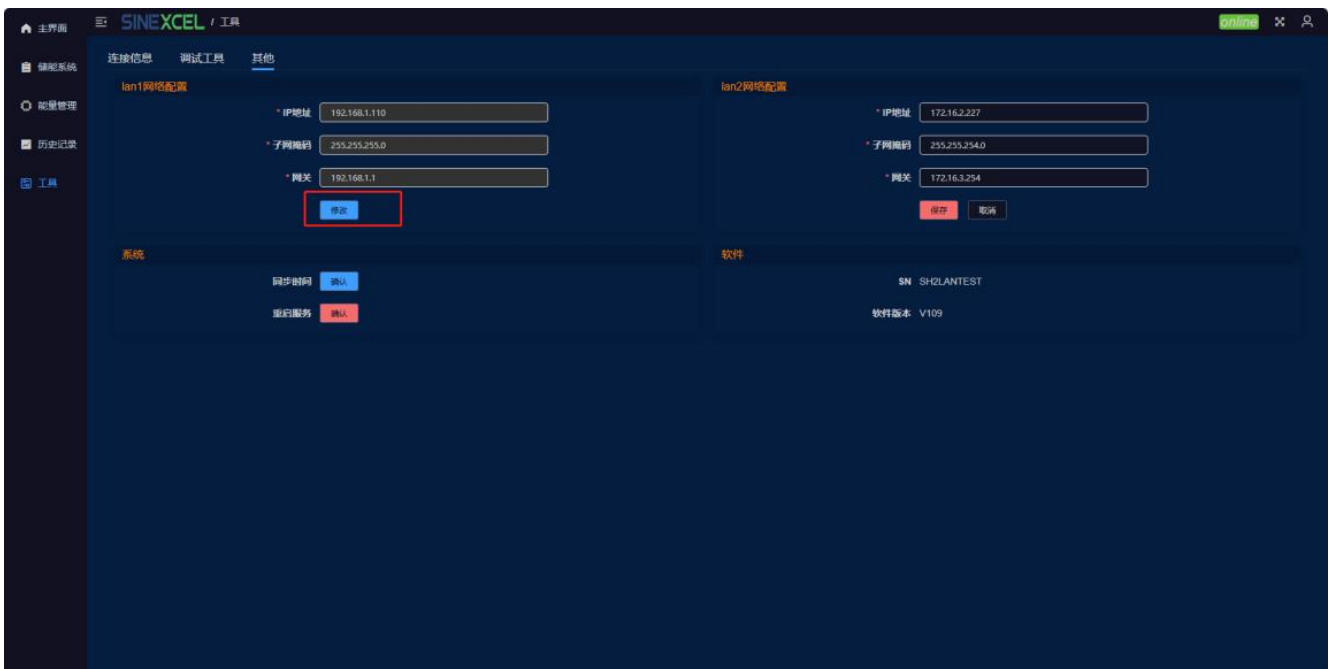

Figure 7.3 IP Modification Page

7.1.3 PCS Module Interface

Go to Tools> Debugging Tools, click the button in Figure 7.4 to open the PCS module interface. Enter your account credentials to operate the PCS module.

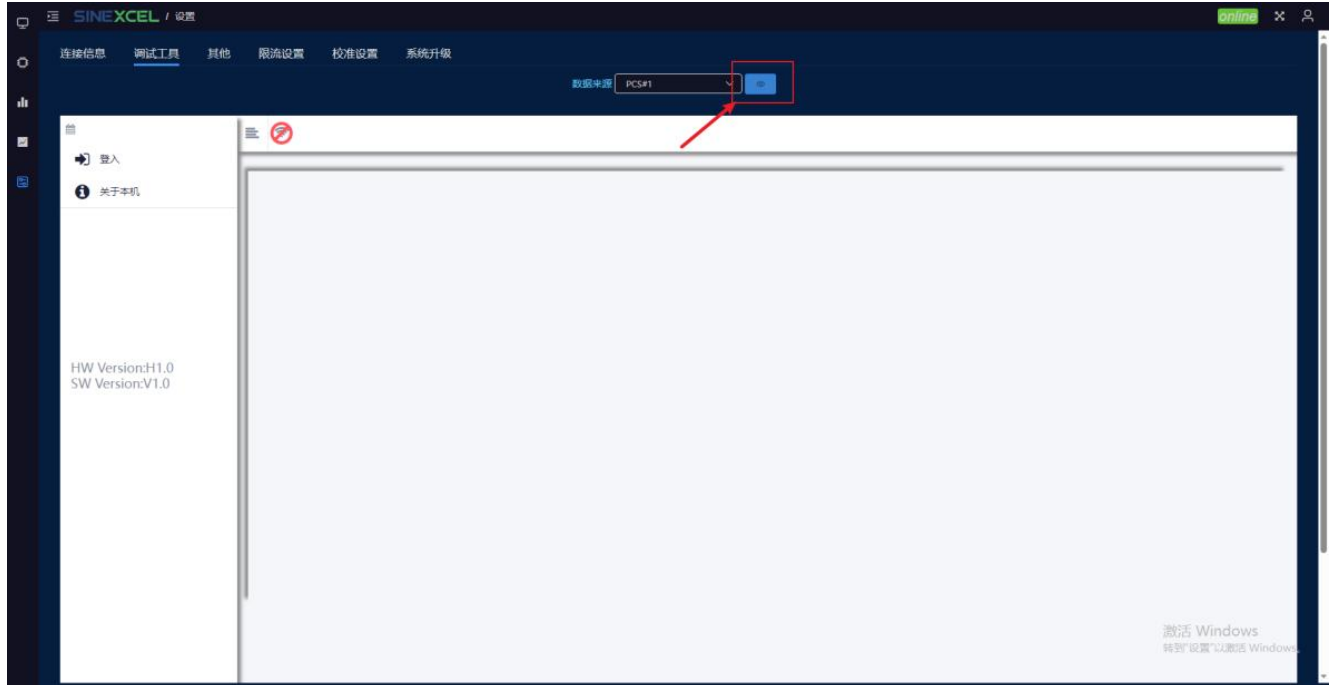

Figure 7.4 PCS module interface entry

7.2 Power on/off

The energy storage device must be fully installed, properly debugged by engineers, and the external power switch must be closed before the startup procedure can be initiated.

7.2.1 Pre-startup Check

Before powering on, follow these steps to check the device:

- 1) Visual inspection confirms no external damage to the equipment, and both the external DC and AC circuit breakers are in the 'OFF' state;
- 2) According to the post-installation inspection items specified in Chapter 6.5.12, verify the proper functioning of the energy storage device's DC input and AC output wiring, and confirm proper grounding;
- 3) Check if the battery voltage is normal;
- 4) Check whether the phase voltage and line voltage on the grid side are within the normal range, and record the voltage values.

7.2.2 Power-on Steps

- 1) Close the DC isolating switches QD1/QD2/QD3/QD4 and AC circuit breakers QF1/QF2/QF3/QF4, along with QF9 (while selectively closing the power supply switches QS2/QS3 of PMS-U2 and the external

DC-side auxiliary power supply switch QF10).

- 2) Verify the rack's status: for grid-connected operation, ensure the PE-N contactor KM1 is open; for off-grid operation, ensure the PE-N contactor KM1 is closed.
- 3) Confirm that the green indicator lights on the rack cabinet door and the PMS-U2 panel are illuminated.
- 4) Open a browser on your computer desktop (Google Chrome is recommended), then enter the machine's default IP address (192.168.1.10) in the address bar. The login interface shown in Figure 7.1 will appear.

Enter 'admin' in the Name field and the initial password '123456' in the Password field. Click 'Log in' to access the PMS-U2 control box backend interface, as shown in Figure 7.1.

In the 'Event Log', the 'Current Alarm' section displays messages such as 'AC #01 AC Busbar Under Voltage' and 'AC #01 AC Busbar Under Frequency'.

The battery DC protection parameters and communication configuration need to be set during the first startup.

- 5) The control box operates in grid-connected mode by default. When the external AC circuit breaker is closed and the machine's AC-side port is powered, the 'AC #01 AC bus under-voltage' and 'AC #01 AC bus under-frequency' alerts displayed in the 'Current Alarm' section will automatically disappear.

7.2.3 Power-off Steps

- 1) Click the Control Scheduling tab on the left side of the webpage, then select the Shut Down command under Control Commands;
- 2) The operation indicator light is off. Check if the device is powered off.;
- 3) Disconnect QF9 (while ensuring that the power supply switches QS2/QS3 for PMS-U2 and the external DC auxiliary power supply switch QF10 are in the open state), AC circuit breakers QF1/QF2/QF3/QF4, and DC disconnectors QD1/QD2/QD3/QD4.

8 Troubleshooting



Warning

Only qualified technicians may perform the operations described in this chapter.

"Meet the requirements" means that the operator has previously undergone professional training in equipment troubleshooting procedures.

Only perform the troubleshooting operations described in this manual.

Follow all safety procedures when operating.

If you still cannot resolve the issue or have questions after using this manual, please contact Shenghong Electric. To provide you with faster and better service, we typically require the following information:

- unit type
- Device serial number
- Manufacturer and model of the device-connected components, as well as the energy storage battery configuration
- The communication connection scheme of the device
- Fault information and brief description
- Photo of the fault location (if conditions permit)

8.1 Preliminary Investigation

If your device malfunctions or shows abnormal charge/discharge patterns, check these items before contacting our maintenance team:

- Open-circuit voltage of energy storage battery meets equipment requirements
- Check if the power grid and DC side are connected correctly and powered on.
- Is the communication cable loose?

8.2 LED Indicator Display and Troubleshooting Methods

Please refer to the following table for device status descriptions

Fig. 8-1 troubleshooting methods

LED status	troubleshooting methods
POWER Indicator light not light up	<p>It means that the PCS rack auxiliary source is powered down, and the troubleshooting method is as follows.</p> <ol style="list-style-type: none">1. Ensure that both the AC side and DC side of the PCS are energized and the voltage is normal.2. Check whether Q1 and QS1, QS1 and QS3 are in closed state, and whether the fuse core of FU3 is intact.3. If the power indicator is still off after the above checks, please contact our service personnel.
RUN Indicator light not light up	<p>It means that the PCS is not in running working condition</p> <ol style="list-style-type: none">1. Whether the system is in the power-on state;

2. Whether the system fault indicator is not in the normally lit state, or whether the system has any alarms. If so, please refer to 9.3 below for troubleshooting.

3. If after the above checks, the operation indicator is still off, please contact our service personnel.

It means that the PCS is malfunctioning and the fault has not been removed.

FAULT Indicator light always on

1. Please check the detailed fault information on the LCD screen or webpage monitor and take appropriate troubleshooting measures.

2. If the indicator still does not light up, please contact our service staff.

8.3 Common Faults and Troubleshooting Methods

Fault type	Possible causes	Simple handling	Remark
DC input overvoltage	DC voltage is higher than the maximum allowable DC voltage	<ol style="list-style-type: none"> 1. Check the configuration of the energy storage battery. 2. Check whether the battery voltage is abnormal, if the battery voltage exceeds the maximum topping charge value, the battery is faulty. 3. Check the protection parameters of DC setting. 4. If after the above troubleshooting, the fault is still reported, please contact our service staff. 	Contact energy storage battery supplier
DC input undervoltage	DC voltage is lower than the minimum allowable DC voltage	<ol style="list-style-type: none"> 1. Check the configuration of the energy storage battery. 2. Check whether the battery voltage is abnormal, if the battery voltage exceeds the maximum topping charge value, the battery is faulty. 3. Check the protection parameters of DC setting. 4. If after the above troubleshooting, the fault is still reported, please contact our service staff. 	Contact energy storage battery supplier
AC busbar overvoltage	Grid voltage is higher than the maximum allowable grid voltage	Check the grid	After the grid voltage is restored to the allowable range, it can be re-allowed.

AC undervoltage	bus	Grid voltage below the minimum allowable grid voltage	Check the grid	After the grid voltage is restored to the allowable range, it can be re-allowed.
AC overfrequency	bus	Grid frequency is greater than the maximum allowable grid frequency	Check the grid	The grid can be manually re-connected after the grid frequency is restored to the allowable range
AC underfrequency	bus	Grid frequency is less than the minimum allowable grid frequency	Check the grid	The grid can be manually re-connected after the grid frequency is restored to the allowable range
Island protection		The PCS detects the occurrence of island phenomenon	Check whether the grid is disconnected, and whether the voltage sampling is abnormal.	The grid can be manually re-connected after the grid frequency is restored to the allowable range
AC bus overload timeout		There is a short circuit at the AC side of the PCS or the internal electronic components are damaged	Troubleshoot whether the external load is too large, and then troubleshoot whether an internal component problem is causing the AC output current to be too large.	Contact Sinexcel
Ambient over-temperature fault		PCS internal temperature is higher than the allowable value	Check if the current ambient temperature is high, then check if the air ducts are blocked and if the fans are operating normally.	If the fault occurs more than 10 times a day, please contact Sinexcel
Module overtemperature fault x(x=1~2)		IGBT module radiator temperature is higher than the allowable value	Maintain the cooling fan after the PCS is completely powered off	If the fault occurs more than 10 times a day, please contact Sinexcel
AC electronic control switch hardware failure		The contactor connected to the power grid inside the equipment fails	Check and repair the contactor after the equipment is completely disconnected	If the fault occurs more than 10 times a day, please contact Sinexcel
DC input electric control switch open circuit		The DC disconnecter connected to the battery inside the equipment is faulty	Refer to the troubleshooting excel sheet.	If the fault occurs more than 10 times a day, please contact Sinexcel
DC input soft start failed		The soft start contactor connected to the battery inside the equipment is faulty	Refer to the troubleshooting excel sheet.	If the fault occurs more than 10 times a day, please contact Sinexcel
DC fuse fault		DC side fuse failure	Refer to the troubleshooting excel sheet.	Contact Sinexcel
Lightning arrester fault		AC side lightning arrester fails	Refer to the troubleshooting excel sheet.	Contact Sinexcel

Auxiliary power failure	DC auxiliary power board is abnormal	Refer to the troubleshooting excel sheet.	Contact Sinexcel
-------------------------	--------------------------------------	---	------------------



NOTICE

Error classification:

Fault - hardware shutdown failure;

Alarm - Shutdown alarm;

Warning - Alarm but not shutdown.

Alarm clearing mode:

Auto - the alarm is cleared automatically after the cause of the alarm disappears;

Manual - the alarm is cleared only after the cause of the alarm disappears and a reset command is sent;

PowerOff - the alarm is cleared only after a power failure and reboot.

The following is simplified to:

Fault Shutdown + Automatic	F.A
Fault Shutdown + Manual	F.M
Fault Shutdown + Power Off	F.P
Alarm shutdown + automatic	A.A
Warning + automatic	W.A
Warning+Manual	W.M

8.4 Other Faults

- The PCS works noisily

Possible causes: abnormal operation of energy storage converter and inductor or the cooling fan is faulty.

Solution:

1/check whether the power is within the normal range, and measure whether the grid-connected current and voltage waveforms are normal. If power is not normal, contact electrical personnel. If power is normal, it is recommended to turn off the machine and contact Sinexcel's personnel.

2/Repair or replace the cooling fan.

- The upper computer cannot communicate

Ethernet communication mode

1. Check whether the IP address, subnet mask and gateway are set correctly.
2. Check whether the communication cable is properly connected.

9 Maintenance

9.1 Safety during maintenance



Danger

High voltage is present in the product's live components. Touching live parts may cause death or serious electrical injury.

Wear appropriate personal protective equipment during maintenance.

Do not touch any live components.

Observe all warning messages on the product and in the documentation.

Comply with all safety information provided by the battery manufacturer.

Before undertaking any work, ensure the external power supply equipment is disconnected from the bidirectional energy storage converter:

- Grid voltage supplied by the mains
- Internal power supply
- DC voltage from the battery
- Additional external voltages, such as control signals from the control room

Ensure disconnected equipment cannot reconnect automatically.

After switching off the equipment, wait at least five minutes before switching it back on to allow capacitors to fully discharge.

Before operating, ensure all components are completely de-energised.

Cover or isolate any adjacent live components.



Attention

Prevent product damage caused by dust ingress and moisture penetration.

Dust or moisture ingress may damage the product and impair its functionality.

Only perform maintenance work in a dry, dust-free environment.

Product maintenance is only permitted when the product is switched off.

Reconnect the external power supply after installing the product.

Should installation or commissioning be interrupted, fit all protective covers. Close and secure the enclosure.

Store the product in a dry location.

9.2 Maintenance plans and spare parts

9.2.1 Operating environment requirements

The installation environment must comply with the operational requirements specified for the equipment:

Permissible ambient temperature: -25 to 60° C

Permissible relative humidity: 0 to 100% (non-condensing)

Maximum permissible altitude: 3,000 metres

Note: Exceeding the maximum altitude will result in derated output from the energy storage converter.

For specific derating factors, please consult our technical personnel.

9.2.2 Electrical and Fixed Connection Inspection

After commissioning, conduct regular inspections of the equipment's electrical and fixed component connections.

It is recommended to perform the inspection every three months. The inspection items include:

- Grounding connections;
- Electrical connections for DC input;
- Electrical connections for AC input;
- Connections for communication and control cables;
- Module fans and rack fans;
- Access to recorded fault information.

9.2.3 Clean and tidy

Before the equipment is put into operation, its radiator, terminals and mesh holes should be cleaned of dust and debris.

After the equipment is put into operation, the dust in the machine room should be cleaned regularly. Check whether the ventilation and exhaust facilities in the machine room are normal. It is recommended to clean every three months.

9.3 maintenance work

- Maintenance intervals should be shortened under adverse environmental conditions.
- Site location and environmental conditions influence maintenance intervals. Pay attention to cleanliness and corrosion prevention.
- More frequent maintenance may be required, with the specific frequency depending on site conditions.
- If DC distribution components are susceptible to adverse environmental conditions, it is advisable to shorten maintenance intervals.
- We recommend conducting regular visual inspections to determine whether maintenance is required.

Consumables and maintenance materials

Consumables and maintenance materials are not typically included in the standard equipment list;
Only professionals or qualified electrical personnel may perform these operations;

Live maintenance work;
Review historical records;
Read error messages and warnings;
Inspect fans;

Non-live maintenance;
Review historical records;
Conduct visual inspections;
Clean ventilation grilles;
Clean air ducts and ventilation ducts;
Inspect internal components;
Check power cord bolt connections;
Inspect labelling;
Inspect door locks, door stops and hinges;

10 Appendix

10.1 Quality Assurance

If a product fails during the warranty period, Shenzhen Sinexcel Electric Co., Ltd. (hereinafter referred to as the Company) will repair or replace it with a new product free of charge..

- Evidence

During the warranty period, our company requires customers to present the invoice and date of purchase of the product. At the same time, the trademark on the product should be clearly visible, otherwise we have the right to not provide quality assurance.

- Conditions

The replaced defective products will be handled by our company.

Customers should allow the Company reasonable time to repair faulty products.

- Waiver of liability

In the following circumstances, our company has the right not to provide quality assurance:

1. The whole machine and its components have exceeded the free warranty period.
2. Shipping damage.
3. Improper installation, modification or use.
4. Operation in very severe environments beyond those specified in this manual.
5. Equipment failure or damage caused by installation, repair, modification or disassembly by anyone other than our company' s service personnel.
6. Equipment failure or damage caused by the use of non-standard or non-Sinexcel parts or software.
7. Any installation and use beyond the scope specified in the relevant international standards.
8. Damage caused by abnormal natural environment.

If the product fails due to the above situation and the customer requires repair service, the paid repair service may be discontinued after the judgment of our service department.

In order to continuously improve customer satisfaction, our company's products and user manuals are in continuous improvement and upgrading. If there is a discrepancy between the user manual in your hand and the product, it may be due to version reasons. Please refer to the specific product. If you still have questions, please contact our company.

11 Contact

If you have a technical issue with our product, call our service hotline. Please provide the following information to receive the necessary assistance.

- Equipment model
- Equipment serial number
- Battery specifications
- Photovoltaic module information
- Current equipment alarm status
- Current AC and DC status of the equipment
- Equipment software version

Shenzhen Sinexcel Electric Co., Ltd.

Website: www.sinexcel.com

Address: Building 6, Zone 2, Baiwangxin High-Tech Industrial Park, 1002 Songbai Road, Nanshan District, Shenzhen

Postcode: 518055

Hotline: +86 755 8651 1588



